

Fig. 1

- Elevated socket strips are available in 5 different standoff heights:
416...006 uses pin # 0153-1
416...003 uses pin # 0153-2
416...007 uses pin # 0153-3
416...008 uses pin # 0153-4
416...001 uses pin # 0153-5
See page 136 for details.
- Hi-Rel, 4-finger BeCu #30 contact is rated at 3 amps. See page 208 for details.
- Insulators are high temp. thermoplastic.

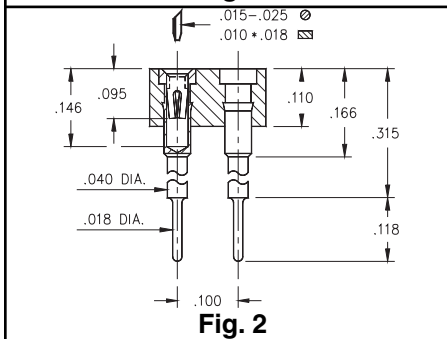
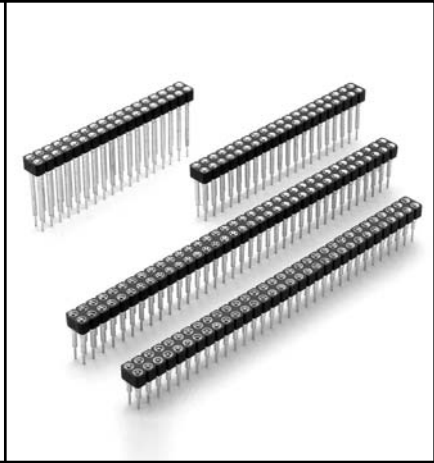

Fig. 2

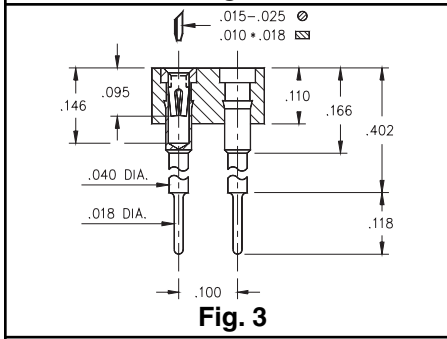

Fig. 3

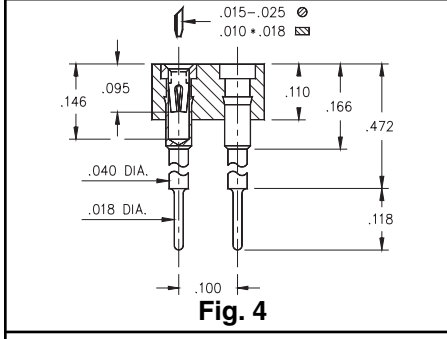

Fig. 4

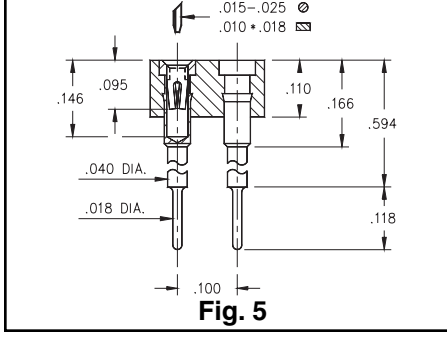

Fig. 5

Ordering Information

Fig. 1	Series 416...006 Standoff Height = .236"
	416-XX-2__-41-006000 Specify # of pins → 02-64
Fig. 2	Series 416...003 Standoff Height = .315"
	416-XX-2__-41-003000 Specify # of pins → 02-64
Fig. 3	Series 416...007 Standoff Height = .402"
	416-XX-2__-41-007000 Specify # of pins → 02-64
Fig. 4	Series 416...008 Standoff Height = .472"
	416-XX-2__-41-008000 Specify # of pins → 02-64
Fig. 5	Series 416...001 Standoff Height = .594"
	416-XX-2__-41-001000 Specify # of pins → 02-64



XX=Plating Code See Below

For RoHS compliance select \diamond plating code.

SPECIFY PLATING CODE XX=	13 \diamond	93		43 \diamond
Sleeve (Pin)	10 μ " Au	200 μ " Sn/Pb		200 μ " Sn
Contact (Clip)	30 μ " Au	30 μ " Au		30 μ " Au